

dermlite

DL200HR

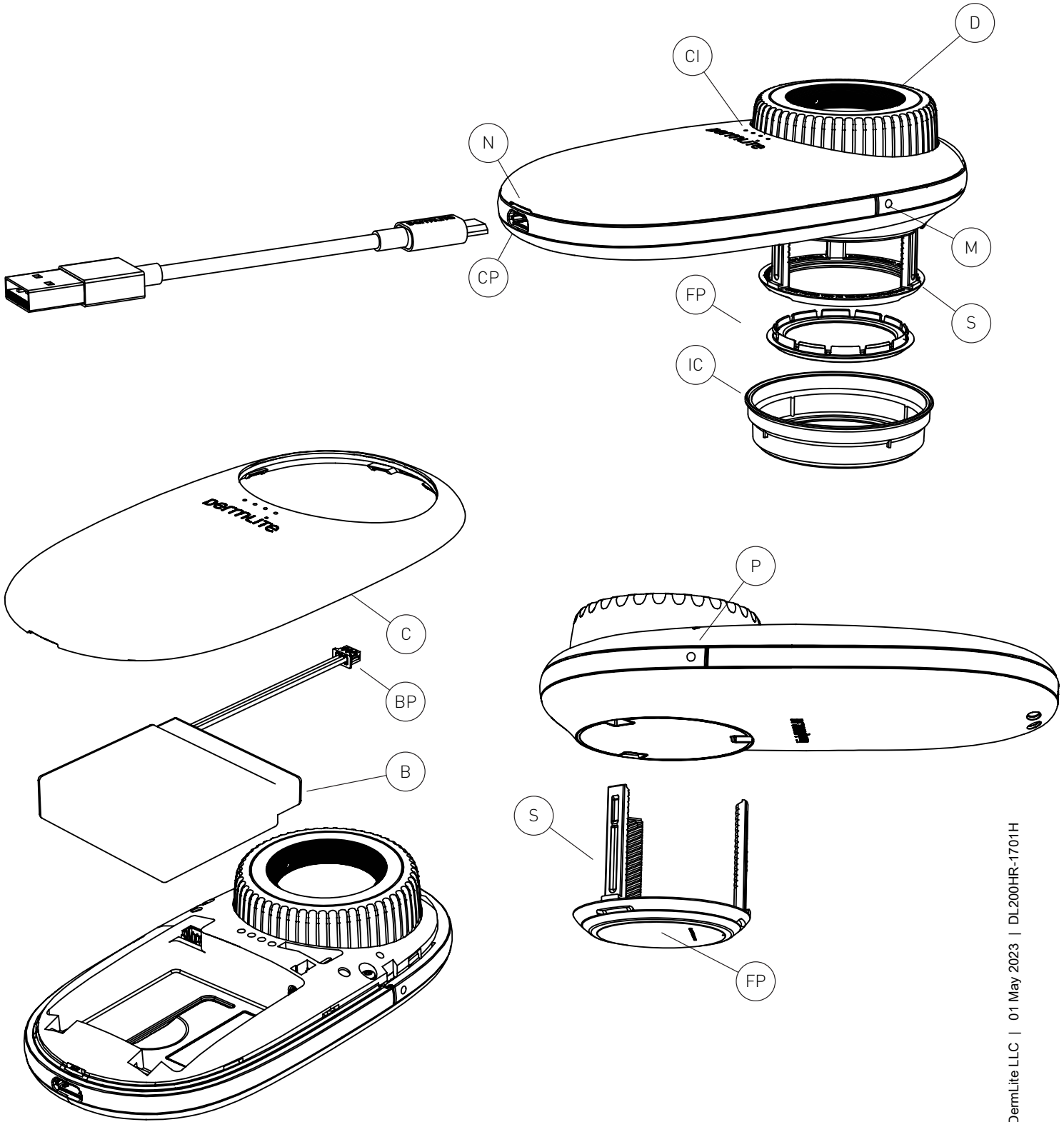

Instructions

Intended Use

This device is intended for medical purposes to illuminate body surfaces. It is used for non-invasive visual examination of intact skin.

This battery-operated product is designed for external examination only within professional healthcare facilities by medical professionals.

Check the correct operation of the device before use! Do not use the device if there are visible signs of damage.

CAUTION: Do not look directly into the LED light. Patients must close their eyes during examinations.

In case of a serious incident with the use of this device, notify DermLite immediately and, if required by local regulations, your national health authority.

CAUTION: Do not use the device in fire or explosive risk area (e.g. oxygen-rich environment).

WARNING: This product can expose you to chemicals including methylene chloride and hexavalent chromium, which are known to the State of California to cause cancer or reproductive toxicity. For more information go to www.P65Warnings.ca.gov.

Electromagnetic Compatibility

This device complies with the EMC Emissions and Immunity level requirements of the standard IEC 60601-1-2:2014. The emission characteristics of this equipment make it suitable for use in professional healthcare environment as well as residential environment (CISPR 11 Class B). This equipment offers adequate protection to radio communication service. In the rare event of interference to the radio communication service, the user might need to take mitigation measures, such as relocating or re-orienting equipment.

WARNING: Use of this equipment adjacent to or stacked with other equipment should be avoided because it could result in improper operation. If such use is necessary, this equipment and the other equipment should be observed to verify that they are operating normally.

WARNING: Use of accessories other than those provided by the manufacturer of this equipment could result in increased electromagnetic emissions or decreased electromagnetic immunity of this equipment and result in improper operation.

WARNING: Portable RF transmitters should be used no closer than 30 cm (12 inches) to any part of the device. Otherwise, degradation of the performance of this equipment could result.

IMPORTANT: Before initial use, please charge the internal lithium ion battery. See "Battery and Charging" for details.

DermLite DL200HR is a smartphone-compatible pocket dermatoscope with 10x magnification intended for polarized examination of skin lesions, with or without skin

contact.

IceCap®

To support your infection control measures, snap one of the included disposable IceCaps (IC) over the installed faceplate (FP). To remove and dispose, simply pull it off.

Hold your device so that the LEDs are aimed at the skin. Position the device ~25mm above the skin and push the Power button (P) to turn on the device. Look through the lens with your eye 25-50 mm above the lens. Move the device closer or farther away from the skin to obtain the desired image focus. For dermoscopy with skin contact, or for camera use, turn the Dial (D) to extend the Spacer (S) and focus the image.

Push the Mode button (M) to choose between two brightness levels.

To turn off your DermLite, push the Power button (P); it turns off automatically after 3 minutes.

Removing the Spacer.

The Spacer (S) may be removed by turning the Dial (D) counter-clockwise beyond a noticeable resistance, then pulling it off the device. To attach the Spacer, insert its 3 legs into the 3 holes until resistance is felt. Place the device level on a flat surface and evenly push down while simultaneously rotating the Dial (D) clockwise.

Removing the Faceplate.

The Faceplate (FP) may simply be pulled off the Spacer (S) by grabbing it at the fingernail notches. To reattach, simply snap it back in place.

Photography.

Your DermLite DL200 may be attached to many cameras or smartphones using DermLite MagnetiConnect® adapters (sold separately). Prior to taking photos, wipe the Faceplate (FP) clean and extend the Spacer (S).

Battery and Charging

CAUTION: This device uses a special 3.7V 1800 mAh lithium ion battery, which can only be purchased from DermLite or from an authorized DermLite dealer. Do not under any circumstances use another battery other than the one designed for this unit. This device is equipped with a four-level Charge Indicator (CI). When the unit is turned on and fully charged, all four LEDs light up. When less than 75% of battery life remains, three LEDs are illuminated. If more than half the battery is drained, two LEDs are on, while a single LED indicates that less than 25% of battery capacity remains. To charge your device, connect the supplied USB-C to USB cable to the Charging Port (CP) and any IEC 60950-1 compliant (5V) USB port. The Charge Indicator (CI) pulses to indicate charging, with the number of pulsing LEDs corre-

sponding with charge level. When charging is complete, all four indicator LEDs illuminate. After years of use, you may wish to re-place the battery, which is only available directly from DermLite or an authorized DermLite dealer.

To remove the battery (B), detach the snap-on Cover (C): Pry it open, starting at the small notch (N), using a screwdriver, then work your way around the Cover to release it completely. Disconnect the Battery Plug (BP), insert a new battery and reconnect. Reattach the Cover securely.

Troubleshooting

Please check www.dermlite.com for the most current troubleshooting information. If your device requires servicing, visit www.dermlite.com/service or contact your local DermLite dealer.

Care and Maintenance

CAUTION: No modification of this equipment is allowed.

Your device is designed for trouble-free operation. Repairs shall be made only by qualified service personnel.

Cleaning

The exterior of your device, except the optical parts, may be wiped clean with isopropyl alcohol (70% vol.) prior to use on a patient. The lens should be treated as high-quality photographic equipment and should be cleaned with standard lens cleaning equipment and protected from harmful chemicals. Do not use abrasive material on any part of the equipment or immerse the device in liquid. Do not autoclave.

Warranty: 5 years for parts and labor. The battery is warranted for 1 year.

Disposal

This device contains electronics and a lithium-ion battery that must be separated for disposal and may not be disposed of with general household waste. Please observe local disposal regulations.

The DermLite DL200 set includes: DL200 dermatoscope (21 LEDs, 25 mm 10x lens, spacer, faceplate with 10 mm reticle), silicone cover, lanyard, microfiber case, USB charging cable, 4 IceCaps.

Technical Description

Visit www.dermlite.com/technical or contact your local DermLite dealer.