

dermlite FotoX

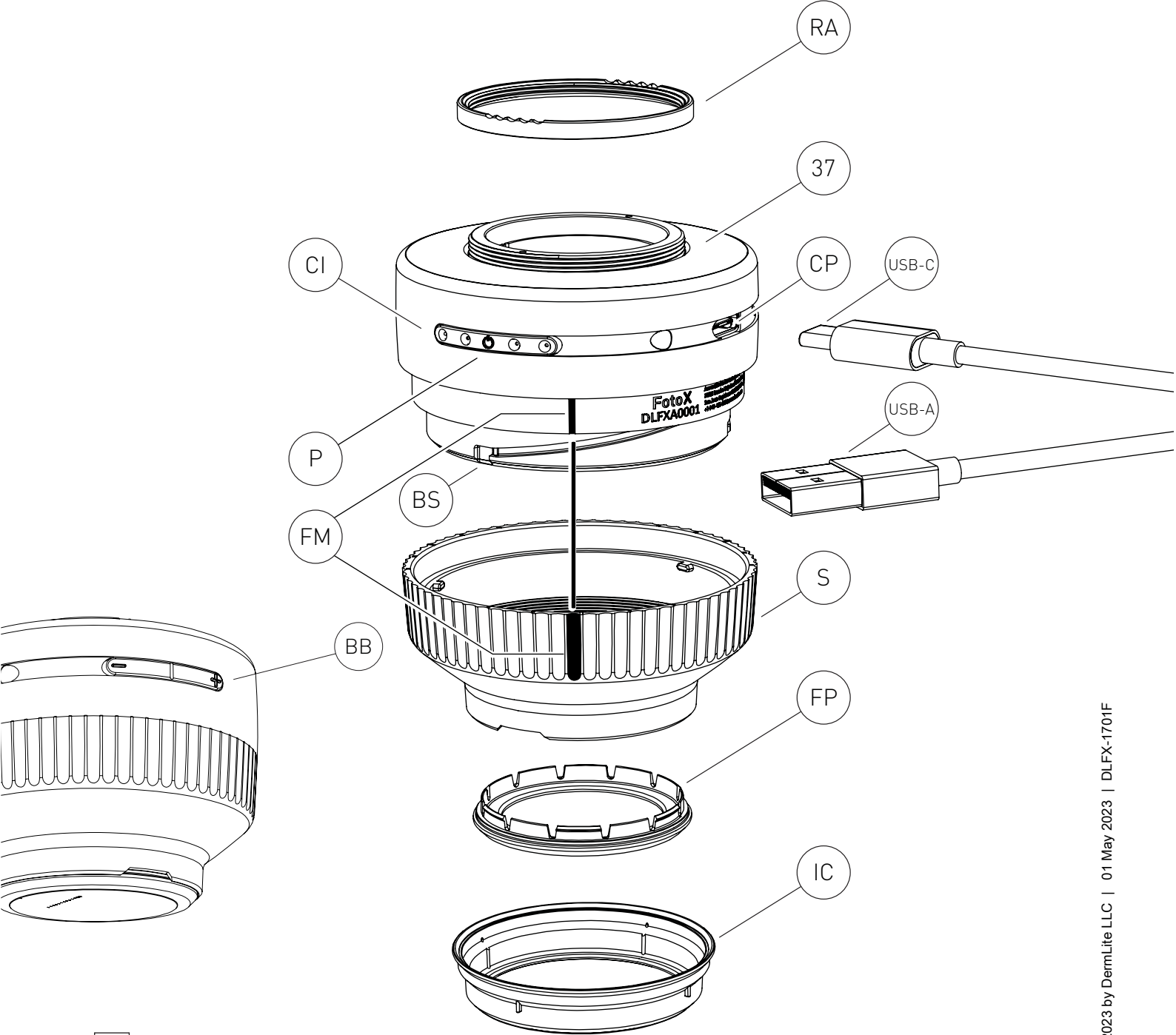

REF DLFX

Instructions

Intended Use

This device is intended for medical purposes to illuminate body surfaces. It is used for non-invasive visual examination of intact skin.

This battery-operated product is designed for external examination only within professional healthcare facilities by medical professionals. Check the correct operation of the device before use! Do not use the device if there are visible signs of damage. CAUTION: Do not look directly into the LED light. Patients must close their eyes during examinations.

In case of a serious incident with the use of this device, notify DermLite immediately and, if required by local regulations, your national health authority.

CAUTION: Do not use the device in fire or explosive risk area (e.g. oxygen-rich environment).

WARNING: This product can expose you to chemicals including methylene chloride and hexavalent chromium, which are known to the State of California to cause cancer or reproductive toxicity. For more information go to www.P65Warnings.ca.gov.

Electromagnetic Compatibility

This device complies with the EMC Emissions and Immunity level requirements of the standard IEC 60601-1-2:2014. The emission characteristics of this equipment make it suitable for use in professional healthcare environment as well as residential environment (CISPR 11 Class B). This equipment offers adequate protection to radio communication service. In the rare event of interference to the radio communication service, the user might need to take mitigation measures, such as relocating or re-orienting equipment.

WARNING: Use of this equipment adjacent to or stacked with other equipment should be avoided because it could result in improper operation. If such use is necessary, this equipment and the other equipment should be observed to verify that they are operating normally.

WARNING: Use of accessories other than those provided by the manufacturer of this equipment could result in increased electromagnetic emissions or decreased electromagnetic immunity of this equipment and result in improper operation.

WARNING: Portable RF transmitters should be used no closer than 30 cm (12 inches) to any part of the device. Otherwise, degradation of the performance of this equipment could result.

IMPORTANT: Before initial use, please

charge the internal lithium ion battery. See "Battery and Charging" for details.

DermLite Foto X is a polarized and non-polarized dermatoscope designed for use with a wide range of cameras and mobile devices.

IceCap®

To support your infection control measures, snap one of the included disposable IceCaps (IC) over the installed faceplate (FP). To remove and dispose, simply pull it off.

Foto X may be attached to many cameras or smartphones via either a magnetic or purely threaded connection. For use with MagnetiConnect® adapters (sold separately), screw the Ring Adapter (RA) onto the 37 mm thread (37). To create a threaded connection with your camera, remove the Ring Adapter (RA) and thread the Foto X onto a compatible camera or threaded camera adapter*. Place the unit onto the skin, then push the Power button (P) to activate the light. Tapping the power button toggles between polarized and non-polarized light. Move between four brightness levels via the Brightness Buttons (BB). To adjust focus, turn the Spacer (S) as needed; aligning the Focus Marks (FM) creates the ideal focal distance for most photography.

To turn off your DermLite, push and hold the Power button (P) for about one second; the unit turns off automatically after 3 minutes.

*Note that many cameras require the use of an additional adapter made by the camera manufacturer or a photography supply company.

Removing the Spacer

The Spacer (S) may be removed by turning it counter-clockwise past a slight resistance. When reattaching, make sure its three small protrusions match up with the Bayonet Slot (BS).

Removing the Faceplate

The Faceplate (FP) may simply be pulled off the Spacer (S) by grabbing it at the fingernail notches.

Battery and Charging

CAUTION: This device uses a special 3.7V 360 mAh (2pcs) lithium ion battery, which can only be purchased from DermLite or from an authorized DermLite dealer. Do not under any circumstances use another battery other than the one designed for this unit.

This device is equipped with a four-level Charge Indicator (CI). When the unit

is turned on and fully charged, all four LEDs light up. When less than 75% of battery life remains, three LEDs are illuminated. If more than half the battery is drained, two LEDs are on, while a single LED indicates that less than 25% of battery capacity remains. To charge your device, connect the supplied USB-C to USB cable to the Charging Port (CP) and any IEC 60950-1 compliant (5V) USB port. The Charge Indicator (CI) pulses to indicate charging, with the number of pulsing LEDs corresponding with charge level. When charging is complete, all four indicator LEDs illuminate. After years of use, you may wish to re-place the battery, which is only available directly from DermLite or an authorized DermLite dealer. To change the battery, contact DermLite or your local DermLite dealer.

Troubleshooting

Please check www.dermlite.com for the most current troubleshooting information. If your device requires servicing, visit www.dermlite.com/service or contact your local DermLite dealer.

Care and Maintenance

CAUTION: No modification of this equipment is allowed.

Your device is designed for trouble-free operation. Repairs shall be made only by qualified service personnel.

Cleaning

The exterior of your device, except the optical parts, may be wiped clean with isopropyl alcohol (70% vol.) prior to use on a patient. The lens should be treated as high-quality photographic equipment and should be cleaned with standard lens cleaning equipment and protected from harmful chemicals. Do not use abrasive material on any part of the equipment or immerse the device in liquid. Do not autoclave.

Warranty: 2 years for parts and labor. The battery is warranted for 1 year.

Disposal

This device contains electronics and a lithium-ion battery that must be separated for disposal and may not be disposed of with general household waste. Please observe local disposal regulations.

The DermLite Foto X set includes: Foto X scope (24 polarized & 8 non-polarized LEDs, 30mm 8x lens), USB-A to USB-C charging cable, 5 IceCaps.

Technical Description

Visit www.dermlite.com/technical or contact your local DermLite dealer.